

ZOOMLION

# ELECTRIC ARTICULATING BOOM LIFTS

## ZA64JE/ZA64JERT-Li

Comply with ANSI/CSA Standard



### HIGHLIGHTS

- ▶ Fast lift system directly lowers the boom from the highest position to the ground, no need to fold the boom to improve work efficiency.
- ▶ Accurate and efficient traveling AC drive system and on-board motion AC drive system provides strong power, stable control and maintenance-free motor.
- ▶ Independent auxiliary power system for more secure application
- ▶ Provide greater work height of 21.45m and lift capacity of 250kg than competitor (ZA64JE Only)
- ▶ Provide greater work height of 21.38m and lift capacity of 250kg than competitor (ZA64JERT-Li Only)
- ▶ Large reduction ratio reducer provides stronger gradeability (ZA64JERT-Li Only)
- ▶ Large-capacity lithium battery features long-lasting battery life, and number of charge and discharge cycles reaches 2500 times, the whole life cycle is maintenance-free, and a 5-year warranty is provided (ZA64JERT-Li Only)



### FEATURES

#### Standard Features

- |                          |                             |
|--------------------------|-----------------------------|
| Proportional control     | Emergency stop button       |
| All motion alarm         | Auto-leveling system        |
| Flashing beacon          | On-board diagnostic system  |
| Self-closing entry gate  | Over tilt protection system |
| Emergency descent system | Oscillating axle (ZA64JE)   |

- Load sensing system
- 4.3' LED display
- Horn

#### Accessories & Options

- AC power to platform
- Air line to platform
- 8.01ftx2.99ft work platform(ZA64JE)
- Non-marking tire

## ACCESS WITH ZOOMLION GREEN

Phone: 1 833 USA-ZOOM  
E-mail: sales@zoomlion-na.com

Add: Zoomlion Heavy Industry NA, Inc. 14215 Two Mile Road, Yorkville, WI 53126  
Web: www.zoomlion-na.com



# ELECTRIC ARTICULATING BOOM- LIFTS

## ZA64JE/ZA64JERT-Li

Comply with CE/ANSI/CSA Standard

Model	ZA64JE		ZA64JERT-Li	
	Imperial	Metric	Imperial	Metric
<b>Size</b>				
Work Height	70ft 4in	21.45m	70ft 1in	21.38m
Platform Height	63ft 10in	19.45m	63ft 7in	19.38m
Horizontal Outreach	39ft 6in	12.05m	39ft 8in	12.1m
Up and Over Height	27ft 1in	8.25m	27ft 1in	8.25m
A - Stowed Length	28ft 7in	8.72m	28ft 10in	8.8m
B - Stowed Width	8ft 1in	2.46m	8ft 1in	2.46m
C - Stowed Height	8ft 3in	2.52m	8ft 3in	2.52m
D - Platform Length	6.00ft (standard) 8.01ft (option)	1.83m (standard) 2.44 (option)	6ft (standard) 8ft (option)	1.83m (standard) 2.44 (option)
E - Platform Width	2.49ft (standard) 2.99ft (option)	0.76m (standard) 0.91 (option)	2ft 6in (standard) 3ft(option)	0.76m (standard) 0.91 (option)
F - Wheelbase	8ft 3in	2.52m	8ft 3in	2.52m
G - Ground Clearance	1ft 1in	0.33m	1ft 4in	0.4m
<b>Performance</b>				
Platform Capacity	550 lb	250kg	550 lb	250kg
Drive Speed	3.79 mph	6.1km/h	3.23 mph	5.2km/h
Gradeability	45%(24°)		45%(24°)	
Axles Oscillation	8in	0.20m	8in	0.20m
Turning Radius (Inside)	9ft 1in	2.78m	9ft 1in	2.78m
Turning Radius (Outside)	18ft	5.49m	18ft	5.49m
Swing	360° continuous/400° non-continuous		360° continuous	
Platform Rotation	±90°		±90°	
H-Tail Swing	2ft	0.6m	2ft 1in	0.64m
Max. Wind Speed	28mph	12.5m/s	27.96mph	12.5m/s
<b>Power</b>				
Battery	24×2V/440Ah		48V/315Ah Li-ion battery	
Charger	48V/60A		48V/60A	
Drive Motor	AC 32V/4.4hp	AC 32V/3.3kW	AC 32V	
Lift Motor	AC 32V/13.4hp	AC 32V/10kW	AC 32V	
Auxiliary Power	12V DC		12V DC	
Hydraulic Tank Capacity	19.8 (us gal)	75L	19.8 (us gal)	75L
Drive	4WD		4WD	
<b>Tire</b>				
Type	33×12 D610 Foam-filled Tires		33×12 D610 Foam-filled tire	
<b>Weight</b>				
Gross	20283 lb	9200kg	20392 lb	9250kg

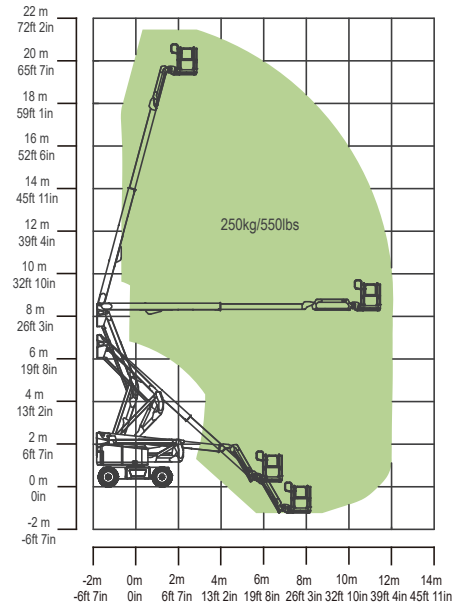
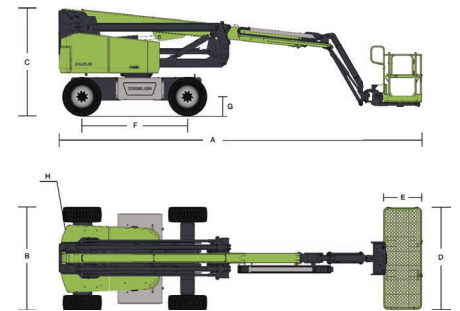

Range of Motion ZA64JE/ZA64JERT-Li